



A NEMA Lighting Systems Division Document

Best Practices for Metal Halide Lighting Systems, Plus Questions and Answers about Lamp Ruptures in Metal Halide Lighting Systems

Prepared by

Lamp and Luminaire Sections
National Electrical Manufacturers Association
1300 North 17th Street, Suite 1752
Rosslyn, Virginia 22209

www.nema.org

LSD 12 and LSD 12A—First Published December 10, 2000
LSD 12 and 12A Combined into LSD 25—May 23, 2002
LSD 25 Last Revised—September 09, 2008

The requirements or guidelines presented in this document, a NEMA Lighting Systems Division white paper, are considered technically sound at the time they are approved for publication. They are not a substitute for a product seller's or user's own judgment with respect to the particular product discussed, and NEMA does not undertake to guarantee the performance of any individual manufacturer's products by virtue of this document or guide. Thus, NEMA expressly disclaims any responsibility for damages arising from the use, application, or reliance by others on the information contained in these white papers, standards, or guidelines.

Contents

Section	Page
1 Introduction	1
2 Objective of This Paper	1
3 Metal Halide Lamp Design Basics	1
4 Metal Halide Arc Tube Failure Mechanisms and Lamp Rupture	2
5 Metal Halide Lamp Classifications	3
6 Change in the 2005 National Electrical Code	3
7 Essential Practices for Minimizing Risks from Metal Halide Lamp Rupture	4
8 Metal Halide Lighting System Luminaire Options & Trade-Offs	4
9 Practices for Minimizing Risk from Metal Halide Systems	5
10 Summary of Commonly Available Metal Halide Systems	7
11 Conclusion	8
12 Questions and Answers about Lamp Ruptures in Metal Halide Lighting Systems	8

Figures	
1 Arc Tube	2
2 Metal Halide Lamp	2



Best Practices for Metal Halide Lighting Systems

1 Introduction

Metal halide lighting systems represent one of the great innovations in lighting applications. Today's systems provide the ability to deliver a variety of light levels, from low to very high output, with high-energy efficiency, long life, and excellent color. In addition, since metal halide lamps are compact sources, these systems offer the ability to direct and focus light in a manner not possible with more diffuse high efficiency light sources, such as fluorescent lamps. Metal halide systems remain the preferred technology for many commercial and industrial applications and, for some, such as sports lighting, virtually the only practical option. Metal halide's ability to deliver the "white light" increasingly preferred in many applications has made it the high-pressure discharge system of choice, and this trend has resulted in the overwhelming success of these systems in the marketplace. NEMA estimates that there are close to 40 million metal halide systems installed in North America alone, with the vast majority in commercial and industrial applications where system efficiency, good color rendering, and life cycle economy are important.

Since metal halide lamps operate at elevated internal pressures compared with most other general-purpose light sources, manufacturers have historically provided explicit instructions on their proper use. In addition, manufacturers provide warning information that is designed to reinforce the need to follow these instructions, since failure to do so can significantly increase the risk of a lamp rupture. A lamp rupture can eject hot particles into the luminaire and, if the luminaire does not completely enclose and contain the hot particles, into the surrounding space. If hot particles land on combustible materials, there is a risk of fire. Despite the large number of metal halide lamps used (over 100 million in the last ten years), there are very few reported instances of property damage claims resulting from the rupture of metal halide lamps. When even this small risk of rupture is not acceptable, enclosed luminaires should be used, or where enclosed luminaires are undesirable, Type-O lamps should be used. The 2005 *National Electrical Code*[®] (NEC) affects the options available for some installations.

NEMA manufacturers have the goal to reduce risk as much as possible without unreasonably sacrificing product utility by continually striving to improve the application and use of metal halide systems.

2 Objective of This Paper

The objective of this paper is to provide educational information for the selection, operation, and maintenance of metal halide lighting systems with specific emphasis on those items pertinent to the risks associated with lamp rupture. The implications of the 2005 NEC provisions on these risks are addressed.

3 Metal Halide Lamp Design Basics

The metal halide lamp is designed around a sealed tube with an electrode in each end (and sometimes with an extra "starting electrode" at one of the ends). See Figure 1. This assembly of a quartz or ceramic tube and electrodes is commonly called the *arc tube*. The arc tube is mounted to a metal frame, sealed within a glass outer bulb, and fitted with a base to form a lamp. See Figure 2.

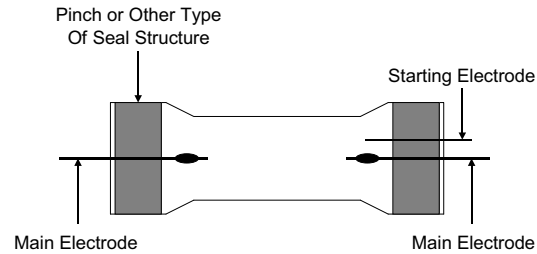
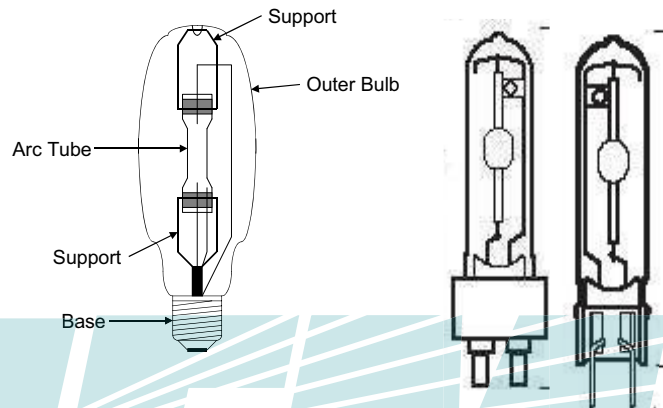

Figure 1
ARC TUBE



(These are representative illustrations. There are many more types.)

Figure 2
METAL HALIDE LAMP

The metal halide arc tube contains a starting gas (typically argon or xenon), mercury, and metal halide salts. The salts most used today consist of iodides of the metals sodium, scandium, and dysprosium. Metal halide arc tubes typically operate at higher temperatures and pressures than mercury vapor arc tubes. Mercury vapor arc tubes operate typically at temperatures of 600-800° C and with contained pressures of 3-5 atmospheres. Metal halide arc tubes operate typically at temperatures of 900-1100° C and with contained atmospheric pressures of 5-30 atmospheres.

4 Metal Halide Arc Tube Failure Mechanisms and Lamp Rupture

Virtually all metal halide lamps reach end of life in a benign manner. However, because of the high internal operating pressure of the arc tube, there is the potential for an arc tube rupture. With only a glass outer envelope surrounding the arc tube, the outer envelope may be breached by particles from an arc tube rupture. If this occurs, hot particles may be ejected from the lamp.

The small, but existing, possibility of a rupture is why most, if not all, lamp manufacturers provide strongly worded warning statements with metal halide lamps.

Chemical reaction of the arc tube wall material with the metal halides may, over time, weaken areas of the arc tube sufficiently that it may fail because of a crack or excessive thinning. If this happens during the heating and cooling that occurs when the lamp is cycled, the result is typically a lamp that

extinguishes and does not re-ignite. If this failure occurs when the arc tube is at full wattage and pressure, the tube may shatter.

5 Metal Halide Lamp Classifications

Every metal halide lamp is classified by the lamp manufacturer as to the recommended manner in which it should be used. The following are the three American National Standards Institute (ANSI) classifications:¹

1. Lamps classified as **Type-E** are to be used only in suitably rated enclosed luminaires, in accordance with UL 1598 and CSA C22.2 No. 250.0.²
2. Lamps classified as **Type-S** have historically been used in both open and enclosed luminaires. Their use in open luminaires is restricted to operation in the vertical position. This category is limited to certain lamps in a 360- to 1000-watt range. A change in the 2005 NEC eliminated the option of using Type-S lamps in open luminaires in those installations regulated by the NEC.
3. Lamps classified as **Type-O** may be used in open or enclosed luminaires. Type-O lamps comply with ANSI Standard C78.389³ for containment testing.

6 Change in the 2005 National Electrical Code

The 2005 NEC⁴ requires luminaires that use metal halide lamps (except for thick-glass PAR lamps) to be either enclosed or to have some physical means to ensure that only Type-O lamps can be used in them. This means that, in practice, open luminaires will utilize a special lamp holder that will accept only Type-O lamps. (Type-O lamps have either a slightly different lamp base (mogul) or bulb neck diameter (medium) than typical Type-E and Type-S lamps.) Since Type-E lamps should only be used in enclosed luminaires, the intent of this change in the NEC is to ensure the use of Type-O lamps in open luminaires for those installations under the jurisdiction of the 2005 NEC.

This change in the NEC reflects experience with the newer technology Type-O lamps in actual installations. This experience is that, even in those rare instances when an arc tube ruptures, the Type-O lamp construction is effective in preventing the rupture particles from penetrating the outer bulb, thus preventing hot particles from falling into the surrounding space. This increased security does not in any way diminish the safety record of the Type-S lamps.

The 2005 NEC⁵ also requires luminaires that use mercury vapor or metal halide lamps, installed in playing and spectator seating areas of indoor sports, mixed-use, or all-purpose facilities to have the lamp protected by a glass or plastic lens. Such luminaires are permitted to have an additional guard. The intent of this change in the NEC is to protect the lamp from physical damage. This reduces the risk of excessive UV exposure, which could result if the lamp outer jacket is broken and the lamp continues to operate. The protection of a lens and possible guard also reduces the risk of falling glass.

¹ ANSI C78.380, Annex B, *American National Standard for Electric Lamps—High Intensity Discharge Lamps, Methods of Designation*, American National Standards Institute, New York.

² UL 1598, *Luminaires*, Underwriters Laboratories Inc., Northbrook, IL. CSA C22.2 No. 250.0-00, *Luminaires*, CSA International, Toronto, Canada. NMX-J-324-ANCE, Association of Standardization and Certification, Mexico. Note that these three standards are the Tri-national Luminaire Safety Standard.

³ ANSI C78.389 *American National Standard for Electric Lamps—High Intensity Discharge – Methods of Measuring Characteristics*, National Electrical Manufacturers Association, Rosslyn, Va.

⁴ 2005 NEC, Article 410.73 (F) (5).

⁵ 2005 NEC, Article 410.4 (E)

7 Essential Practices for Minimizing Risks from Metal Halide Lamp Rupture

To significantly reduce the risk of lamp rupture, the lamp manufacturer's warnings and operating instructions must be followed.

Furthermore, all NEMA lamp manufacturers strongly recommend that lamps be group replaced at or before their rated life.

NEMA lamp manufacturers require that some types of metal halide lamps be turned off at least once a week for a minimum of 15 minutes to reduce the possibility of rupture in continuously operating installations. However, they no longer require that Type-O lamps be turned off once a week for a minimum of 15 minutes in continuously operating installations since Type-O lamps incorporate an integral self-shielding technology designed to minimize any ejection of hot particles from the lamp. While not required, some manufacturers note that cycling can be employed as an additional measure if possible failure of the lamp containment mechanism would be considered unacceptable in a given installation.

8 Metal Halide Lighting System Luminaire Options & Trade-Offs

Metal halide luminaires are available for myriad applications including retail stores, commercial office space, manufacturing plants, warehouses, sports lighting, and roadways. Each of these applications has very different light distribution and control needs. It is primarily the job of the luminaire to take the light produced by the light source and to distribute it within the application space. To satisfy the diverse range of performance and economic criteria that exist, a wide variety of luminaire designs, with differing optical configurations and capabilities, have been developed.

For instance, many manufacturing facilities have high ceilings. Industrial high bay luminaires have been developed to provide narrow photometric distributions that control glare within the normal field-of-view of those occupying the space. Luminaire reflectors with open bottoms or reflectors with simple flat lenses/enclosures are often applied in such applications.

Luminaires for use in spaces with lower mounting heights, such as many commercial retail stores, can produce excessive visual glare in the normal field-of-view if they were supplied either without lenses or with flat glass lenses. For these lower mounting heights, "low bay" luminaires are frequently designed with prismatic lenses. These lenses serve to optically redirect the light produced from the luminaire into a broad, even pattern within the space and also reduce the brightness of the luminaire to a level that is visually comfortable for the occupants of the spaces.

Lower wattage metal halide lamps are often used in luminaires for commercial spaces, including down-lights, adjustable accent units, and track lighting. While some of these luminaires incorporate a lens, some architectural applications demand luminaires with specific optical and/or thermal performance characteristics that would be adversely impacted by inclusion of a lens. Accordingly, Type-O lamps are typically employed. PAR lamps, which have integral reflectors and thick glass envelopes, are also used where the lamp is relied upon to provide optical control.

Many luminaires are offered with the option of including special lamp holders that allow a Type-O lamp to be used, but prevent a Type-E or Type-S lamp from being successfully installed in the luminaire. Such constructions are standard for those open luminaire installations that comply with the 2005 NEC.

There are reasons, driven by application needs, to offer both *open* and *enclosed* luminaires. Users should assess the consequences of a possible ruptured arc tube (and broken outer bulb) when choosing a lighting system. Relative to Type-S lamps in open luminaires, both enclosed luminaires and Type-O lamps in open luminaires offer more protection in the event of arc tube rupture. It is therefore important to include risk management as a selection criterion. It is not practical to simply dictate that all luminaires be one type or the other.

The following factors need to be considered in any choice of system components:

- Desired maintained light level
- Light distribution pattern
- Number of luminaires required
- Efficiency of the system
- Initial acquisition and installation costs
- Cost of operating the system—electricity
- Cost and ease of maintenance—cleaning luminaires, changing lamps
- Probable conditions at the site once in use
- Level of acceptable risk from a ruptured arc tube
- Specifier requirements
- Aesthetics

The final decision by any end user is typically a combined consideration of all factors.

9 Practices for Minimizing Risk from Metal Halide Systems

The following practices should be followed, regardless of the specific type of metal halide system that is installed and regardless of the specific use or application environment (store lighting, warehouse, industrial, indoor sporting facilities, etc.)

1. Users must become familiar with and heed the lamp and luminaire manufacturers' warnings and follow their instructions with respect to safety, installation, maintenance, and reduction of risk. This information can be found on the product packaging or insert sheet, in separate literature for the product, on web sites, or in published catalogs. The user's failure to follow the manufacturers' warnings and instructions will increase the risk for those installations. NEMA manufacturers have professional applications experts who can assist users if they have additional questions regarding any aspect of application.
2. Always group re-lamp metal halide installations at the time recommended by the lamp manufacturer. Although some spot re-lamping may be necessary for any installation, using spot re-lamping as the only replacement practice increases risk and is strongly discouraged.
3. Follow lamp manufacturer instructions for lamp cycling⁶ as may be applicable for specific lamp types. Products are available that will automatically cycle lamps/luminaires, either on a scheduled or random basis depending upon what is best for a user's needs. Such automatic cycling controllers, which can be as simple as a time clock, can be installed for both new and existing metal halide applications.
4. Operate metal halide lamps on ballasts that are designed to provide the appropriate wattage for the lamp. Ballasts should be compliant with UL 1029 or CSA C22.2 No. 74.0⁷ and follow ANSI lamp wattage requirements. Operating the lamp on an incorrect ballast can increase the risk of lamp failure.

⁶ Cycling means turning off lamps at least once per week for a minimum of fifteen (15) minutes when they are in continuous operation.

⁷ UL 1029, *Ballasts, High Intensity Discharge Lamp*, Underwriters Laboratories Inc., Northbrook, IL. CSA C22.2 No. 74.0-96, *Equipment for Use with Electric Discharge Lamps*, CSA International, Toronto, Canada.

5. Ensure that luminaires for metal halide lamps are third party listed to UL 1598 or CSA C22.2 No. 250.0 by an accredited NRTL.⁸
6. When installing and maintaining luminaires, ensure that all manufacturer-supplied components are installed properly. Failure to install supplied components, such as a lens, will void third party listing. The user's failure to install a lens properly during luminaire installation or during routine maintenance could increase the risk of hot particles escaping the luminaire in the unlikely event of a lamp rupture.
7. The luminaire manufacturer must be consulted if a user wishes to add a protective lens to an existing luminaire. In some instances, the addition of a lens may still leave an opening at the top of the reflector, which could allow the ejection of hot particles. Adding a cover lens to a luminaire where none was intended can raise both the lamp and ballast temperatures to unacceptable levels, increasing risk of failure. In addition, lens covers, when used, must themselves be operated within approved temperature limits for correct performance as a safety device. Failure to consult the luminaire manufacturer when adding such a cover may void its third party listing.
8. Follow lamp manufacturer and NEMA recommendations and guidelines for dimming metal halide lamps.⁹ Excessively deep dimming (beyond manufacturer and industry guidelines) may increase the risk of rupture for some metal halide lamps. If dimming is to be employed, consult the lamp manufacturer for recommendations.
9. Special care should be taken when storing flammable, combustible, or oxidizing materials under metal halide luminaires. For example: in warehouse applications, locate luminaires over the center of aisles.
10. Do not use luminaires in an application where the ambient temperature exceeds the rated temperature for the luminaire.
11. Damaged lenses must be replaced immediately. Failure to replace a damaged lens increases the risk that the luminaire will not adequately contain a lamp rupture if one should occur.
12. Comply with all applicable codes, including the 2005 NEC.

⁸ NRTL stands for a Nationally Recognized Testing Laboratory, accredited by the Occupational Safety and Health Administration.

⁹ NEMA publication LSD 14-2002, *Guidelines on the Application of Dimming to High-intensity Discharge Lamps*, National Electrical Manufacturers Association, Rosslyn, VA.

10 Summary of Commonly Available Metal Halide Systems

This section presents various common system options and the advantages and disadvantages of each. The underlying assumption is that all manufacturers' warnings and instructions are followed. See the table below.

Commonly Available Metal Halide Systems

System Description	Advantages	Disadvantages
<ul style="list-style-type: none"> • Open Luminaire • S-type Lamp <p>NOTE—This system does not comply with the 2005 NEC.</p>	<ul style="list-style-type: none"> • Lowest initial cost system • Fewer luminaires and less energy consumption than the same product with a lens (for a specified illumination level) • No lens to maintain or to reduce light output • Easy lamp replacement • Typically shorter hot re-strike time than for enclosed luminaires 	<ul style="list-style-type: none"> • No extra containment barrier • Only available for lamps between 360 and 1000 watts • Required vertical lamp operation limits available luminaire types • Does not prevent mis-lamping with Type-E lamp • Lamp more susceptible to damage than in enclosed luminaire
<ul style="list-style-type: none"> • Open Luminaire • O-type Lamp (Non-exclusionary Lamp Holder Design) <p>NOTE—This system does not comply with the 2005 NEC.</p>	<ul style="list-style-type: none"> • Provides a containment barrier within the lamp • Fewer luminaires and less energy consumption than same product with a lens (for a specified illumination level) • No lens to maintain or to reduce light output • Easy lamp replacement • Typically shorter hot re-strike time than in enclosed luminaires 	<ul style="list-style-type: none"> • Higher lamp cost • Does not prevent replacement with Type-S or Type-E lamps • Lamp more susceptible to damage than in an enclosed luminaire • Type-O lamps may have slightly reduced lumen output compared to Type-S or Type-E lamps of similar design
<ul style="list-style-type: none"> • Open Luminaire • O-type Lamp (Exclusionary Lamp Holder Design) <p>NOTE—This system complies with the 2005 NEC.</p>	<ul style="list-style-type: none"> • Provides a containment barrier within the lamp • Does not allow Type-S or Type-E lamps to be installed • Fewer luminaires and less energy consumption than the same product with a lens (for a specified illumination level) • No lens to maintain or to reduce light output • Easy lamp replacement • Typically shorter hot re-strike time than in enclosed luminaires 	<ul style="list-style-type: none"> • Higher lamp and lamp holder cost • Lamp more susceptible to damage than in enclosed luminaire • Type-O lamps may have slightly reduced lumen output than Type-S and Type-E lamps of similar design
<ul style="list-style-type: none"> • Third Party Listed Plastic Lens Luminaire • Type-S, -O, and -E Lamps <p>NOTE—This system complies with the 2005 NEC.</p>	<ul style="list-style-type: none"> • Provides external containment barrier • Can use Type-S, -O, or -E lamps • May be required for certain applications (food handling, etc.) • Prismatic lenses may provide better lighting performance 	<ul style="list-style-type: none"> • Higher initial cost than open systems • Not available in higher wattages and ambient temperature ratings • Requires operation within stated ambient temperature for proper containment • Potential degradation of lens over time • Degradation or damage of lens requires replacement • More difficult to re-lamp than open luminaire

Table continued next page

Commonly Available Metal Halide Systems (Continued)

System Description	Advantages	Disadvantages
<ul style="list-style-type: none"> • Tempered or Borosilicate Glass Lens Luminaire • Type-S, -O, and -E Lamps <p>NOTE—This system complies with the 2005 NEC.</p>	<ul style="list-style-type: none"> • Provides external containment barrier • Can use Type-S, -O, or -E lamps • Can be used in higher temperature environments and with higher wattage lamps than comparable product with plastic lens • Potential for longer lens life than plastic • Prismatic lenses may provide better lighting performance 	<ul style="list-style-type: none"> • Higher initial cost than open system • Potential for lens shattering due to mechanical stress • Tempered glass can shatter due to thermal shock or spontaneous breakage • Damaged lens requires replacement • Heaviest system • More difficult to re-lamp than open luminaire

11 Conclusion

Metal halide lamps and systems offer very significant benefits to users. Metal halide systems offer distinct performance features that will continue to make them the optimum system choice for many applications.

To reduce the risk of rupture from such systems, users should carefully follow manufacturers' warnings and instructions. Users should study the industry information provided in this report to make informed choices when considering whether existing or new systems are being operated or specified in a manner that appropriately assesses risk and when considering which additional measures may be appropriate based on individual circumstances.

Manufacturers of metal halide lamps and luminaires should be consulted if there are specific questions regarding their products that may relate to any of the topics in this report. Lighting users that do not understand the terminology or content of this paper should consult a lighting professional.

NEMA manufacturers are committed to providing the finest metal halide products available for all applications. This information will be periodically reviewed and updated. NEMA manufacturers reserve the right to revise and change the information, recommendations, and guidelines contained within this report, as appropriate.

12 Questions and Answers about Lamp Ruptures in Metal Halide Lighting Systems

Q: Why is NEMA publishing this White Paper?

A: NEMA manufacturers want to ensure that any potential lamp rupture risk from metal halide lighting systems remains low. Manufacturers will periodically update important information related to safety and will reinforce the importance of following all the instructions and warnings associated with any product, including metal halide lighting systems. Although each manufacturer individually provides and stresses the information related to safe operation of metal halide systems, NEMA members believe a collective industry effort will result in an even greater level of overall safety since more of the best practices will be followed by the end user.

Q: Is there a risk associated with metal halide lighting systems?

A: The use of any electrical product poses some degree of risk. Metal halide lamps contain arc tubes that operate under high pressure and that may rupture unexpectedly. If a rupture occurs that is forceful enough to break the outer envelope, hot fragments from the lamp could conceivably become an ignition source in some applications. Where the highest protection from such rare occurrences is needed, the use of Type-O lamps or enclosed luminaires is recommended. Type-S metal halide lamps are rated for use in open luminaires *provided that* all the lamp manufacturers' instructions and warnings are followed. But, Type-S lamps are not suitable for all applications. For example, applications near flammable or combustible material should use Type-E or Type-O alternatives.

Q: Why are Type-S lamps used today despite the availability of other options?

A: More than 30 years of field history has shown that Type-S lamps, when operated according to manufacturers' instructions and warnings, represent a very small risk in most applications and provide many end user benefits in a cost effective manner. Where it makes sense for Type-S lamps to be used in open luminaires depends very much on the specific application and whether end users follow all manufacturers' instructions. These lamps should not be used in open luminaires unless ALL warnings and instructions of the lamp and luminaire manufacturers are completely followed. If there is any doubt that operators or maintenance personnel will completely follow manufacturers' instructions, then only Type-O lamps should be used in open luminaires. For those applications falling under the jurisdiction of the 2005 NEC, Type-S lamps cannot be used in new open-luminaire installations.

Q: What about installations that already use Type-S lamps in open luminaires? Are they safe with respect to changes to the 2005 NEC?

A: Existing installations that use open luminaires and Type-S lamps will continue to exist, even in municipalities that adopt the 2005 *NEC*. Type-S metal halide lamps will continue to be available for those customers that wish to continue to use them in existing open luminaires and in accordance with appropriate lamp and luminaire manufacturer warnings and instructions. When operated in accordance with such warnings and instructions, open luminaires with Type-S lamps remain a safe option in suitable applications.

Q: What does NEMA expect will happen to open luminaires with Type-S lamps in the future?

A: It is expected over time that the mix of metal halide installations and available lamps will naturally shift to reflect the anticipated adoption of the 2005 *NEC* both for new installations and as existing installations are replaced or renovated.

Q: Why do group re-lamping and lamp cycling reduce the potential for metal halide lamp rupture?

A: *Group re-lamping* at or before lamps reach their published rated life removes these lamps from service before the point in time when the probability of arc tube rupture increases. Although many lamps will last thousands of hours beyond their published rated life, the arc tube and internal chemicals (metal halide salts) continue to react at the high temperatures inside the arc tube. Thus, deterioration (devitrification) of the quartz tube, or chemical attack of the ceramic arc tube, continues to the point where violent arc tube failure may occur. In addition, beyond the published rated life, light output diminishes further and color shifts occur so the lamps no longer operate with their designed performance characteristics.

Cycling the lamps helps to cause the lamps nearing end-of-life to fail benignly.¹⁰ As lamps age, stresses in the arc tube gradually increase. If the stresses are severe enough, they can cause the arc

¹⁰ By cycling it is meant turning off lamps at least once a week for a minimum of fifteen (15) minutes when they are in continuous operation.

tube to crack. Under operating conditions, the combination of a crack and high pressure in the arc tube can cause a rupture. However, if the lamp is periodically cycled, the cooling down or heating up of the arc tube can cause those cracks to propagate while the internal arc tube pressure is low, preventing a violent failure.

Q: Are there similar rupture risks from other high-pressure discharge systems?

A: Mercury vapor lamps also contain arc tubes, which operate at high pressures. However, the pressures and temperatures are not as high as those of metal halide arc tubes, and the chemicals in these lamps are less aggressive toward the quartz. Nevertheless, some ruptures have occurred due to thermal or mechanical stresses on the arc tube.

High-pressure sodium (HPS) arc tubes operate at lower internal pressures than either metal halide or mercury vapor arc tubes. In fact, the operating pressure of an HPS arc tube is very close to one atmosphere, so that even if a crack occurs, there is no high pressure to cause a violent rupture.

Q: How should I treat “pulse starting” metal halide systems?

A: These lamps should not be treated any differently than standard metal halide lamp systems in terms of application and potential for arc tube rupture. The manufacturer’s warnings and instructions, as always, should be read and followed.

Q: Should I use exclusionary lamp holders with Type-O lamps?

A: Although Type-O lamps will operate in standard lamp holders, exclusionary lamp holders are strongly recommended to prevent a non-Type-O lamp from being installed. Type-S and Type-E lamps will not start if installed in exclusionary lamp holders. The NEC requires that exclusionary lamp holders be used in new open-luminaire installations for those applications falling under its jurisdiction.

Q: How can I tell if I have a Type-O or Type-S lamp?

A: Metal halide lamps are required to be marked with an ANSI code that includes the luminaire type. An example of the code on a metal halide lamp is M59/E, where:

- M indicates a metal halide lamp with a quartz arc tube
- 59 is the electrical code that matches the lamp and ballast, and
- E indicates that an enclosed luminaire is required

In case of doubt, contact the lamp manufacturers.

Q: What tests are performed to verify the Type-O rating of metal halide lamps?

A: The American National Standard test procedures for quartz and ceramic metal halide lamps are described in document ANSI C78.389.¹¹ The tests increase the energy in a number of arc tubes in order to cause a rupture. The subsequent ruptures must be totally contained within the outer bulbs to meet the requirements of the Type-O rating. Lamp manufacturers use these test procedures before applying the Type-O rating to their lamps.

Q: What does it mean when a luminaire is “third party listed”?

A: In order to comply with the *National Electrical Code* (NFPA-70)¹² and the majority of local ordinances, luminaires must be examined by a qualified electrical testing laboratory and found to meet

¹¹ ANSI C78.387, *American National Standard for Electric Lamps— High Intensity Discharges, Methods of Measuring Characteristics*, American National Standards Institute, New York.

¹² For the *National Electrical Code* definition of the term listed, see Article 100.

nationally recognized safety standards or be tested for a specific purpose. The testing laboratory must be acceptable to the authority having jurisdiction (local building/electrical inspector), publish a record of the examination, and conduct ongoing inspections of the luminaire model at the production facility. Most testing laboratories authorize the use of a special label on compliant luminaires that indicates that the luminaire is listed.

Q: How do I match the correct metal halide lamp to a metal halide luminaire?

A: Listed luminaires are provided with lamp/re-lamp information on a label affixed to the luminaire. This information prescribes the specific lamp wattage and lamp type necessary to correctly match the proper lamp that is intended for use with a specific metal halide luminaire. This information may or may not also be included in part or in its entirety on an instruction sheet provided with the luminaire. End users should always adhere to the precise labeling and instructional information provided with each and every luminaire.

Q: How do I know what the temperature rating is for a luminaire?

A: Many luminaires are designed and tested with the assumption that they will be installed at locations maintained at a maximum ambient temperature of 25°C (77°F). Some luminaires are specially engineered and evaluated for installation where elevated ambient temperatures are anticipated. Luminaires listed for elevated ambient temperature are marked to indicate the maximum suitable ambient temperature and sometimes include special installation instructions that must be followed.

Q: Does the environment in which the luminaire operates affect lamp containment?

A: The environmental application of the luminaire must be considered over the life of the product. The environmental conditions surrounding the luminaire can degrade the luminaire materials used for lamp containment. Environmental compatibility in conjunction with acrylic or polycarbonate lamp containment enclosures must be evaluated when airborne chemicals are present in the environment. The materials used in construction for the lamp containment barrier can be impacted by the presence of these chemicals when they become airborne and react with the luminaire. Probable conditions that may cause breakage of the containment enclosure should also be considered. In some applications, it may be appropriate to use a wire guard external to an acrylic or polycarbonate enclosure. Each application is different, and it is best to consult the manufacturer on individual questions when these types of conditions exist.

Q: Is there any value in continuing to cycle Type-O lamps in some situations?

A: In the past, NEMA lamp manufacturers required that some types of metal halide lamps be turned off at least once a week for a minimum of 15 minutes if operating in a continuous mode. This is no longer a requirement for Type-O lamps because they incorporate an integral self-shielding technology designed to minimize any ejection of hot particles from the lamp in case of arc tube rupture. Cycling Type-O lamps may be recommended by some manufacturers as an added precaution to reduce the number of overall ruptures that might potentially occur over time in a continuously operating installation.

§